

V-1230R

탈착식 사용 지침

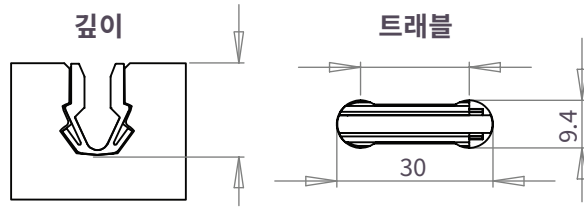

1. 밀링

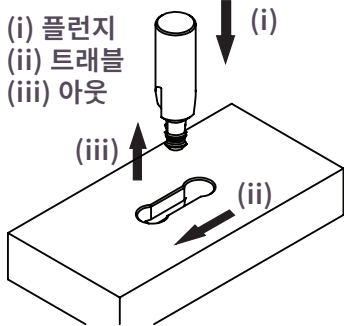

권장 설정
 깊이: 12.9mm, +/- 0.1mm
 트래블 중심간 이동: 22mm
 회전 속도: CNC 속도는 재료에 따라 다릅니다.
 최대 커터 회전 속도: 18,000

권장 간격

(a): 35mm에서 80mm 까지
 (b): 100mm에서 250mm까지

조립구간

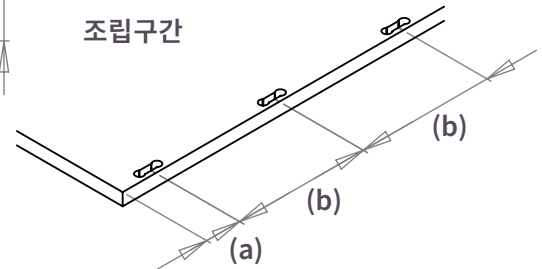

2. 하우징

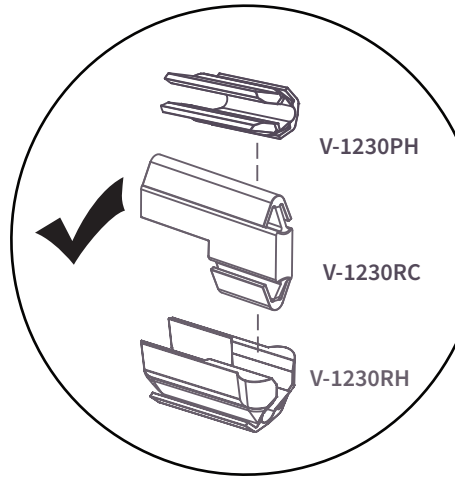
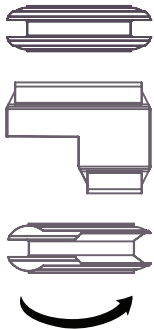

제위치에 밀어 넣기

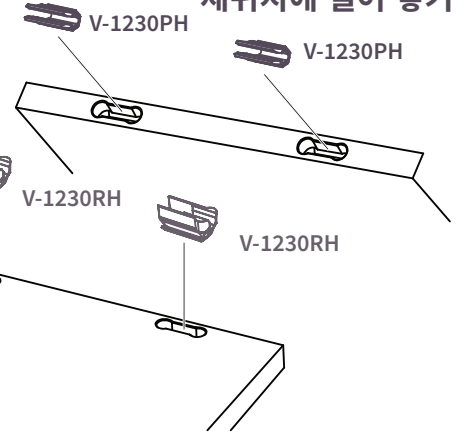

3. 조립 - 간단하게 밀어서 연결

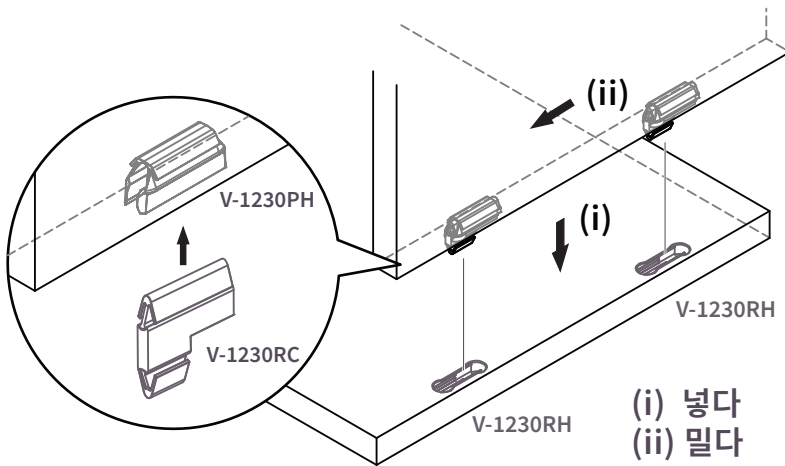

4. 연결해제

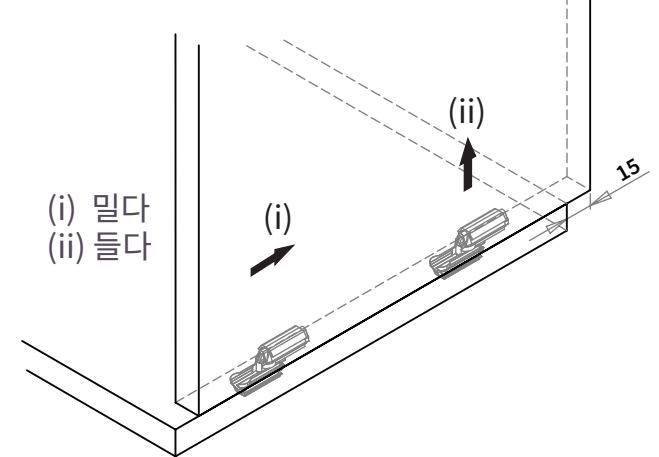

작동 방식

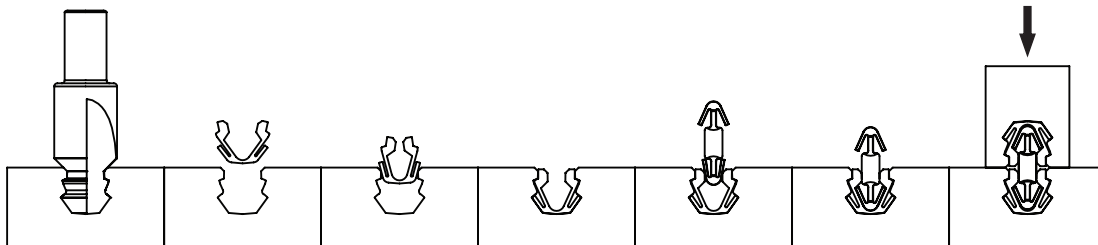

간단하게 밀어서 연결

