

# 사용 지침

## PD10 + V1230PH

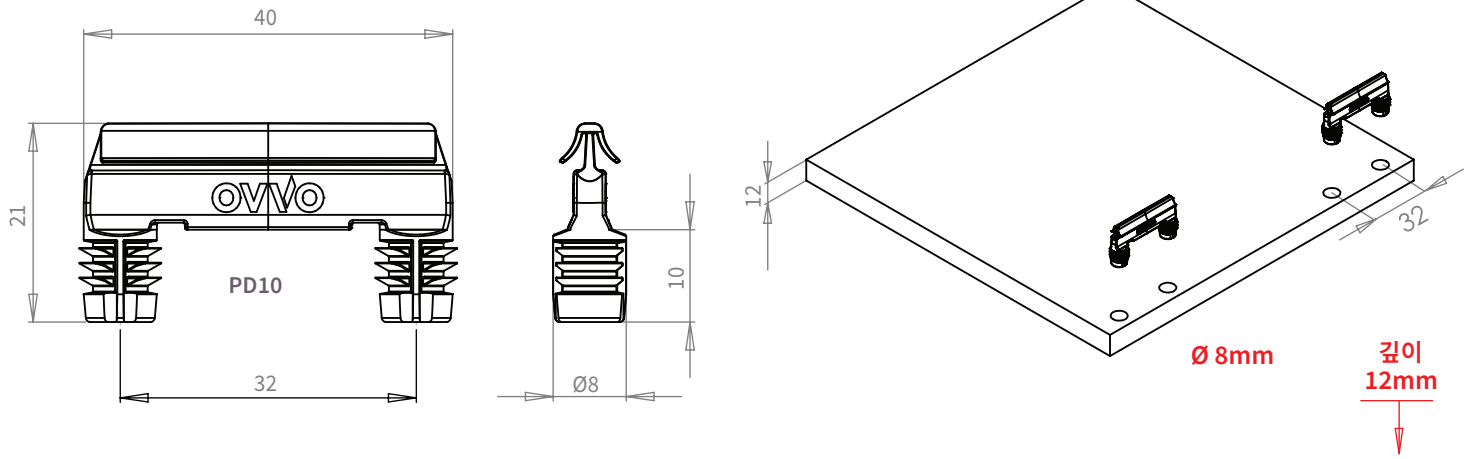

### 1. PD10을 위한 드릴링



### 2. V-1230PH를 위한 밀링

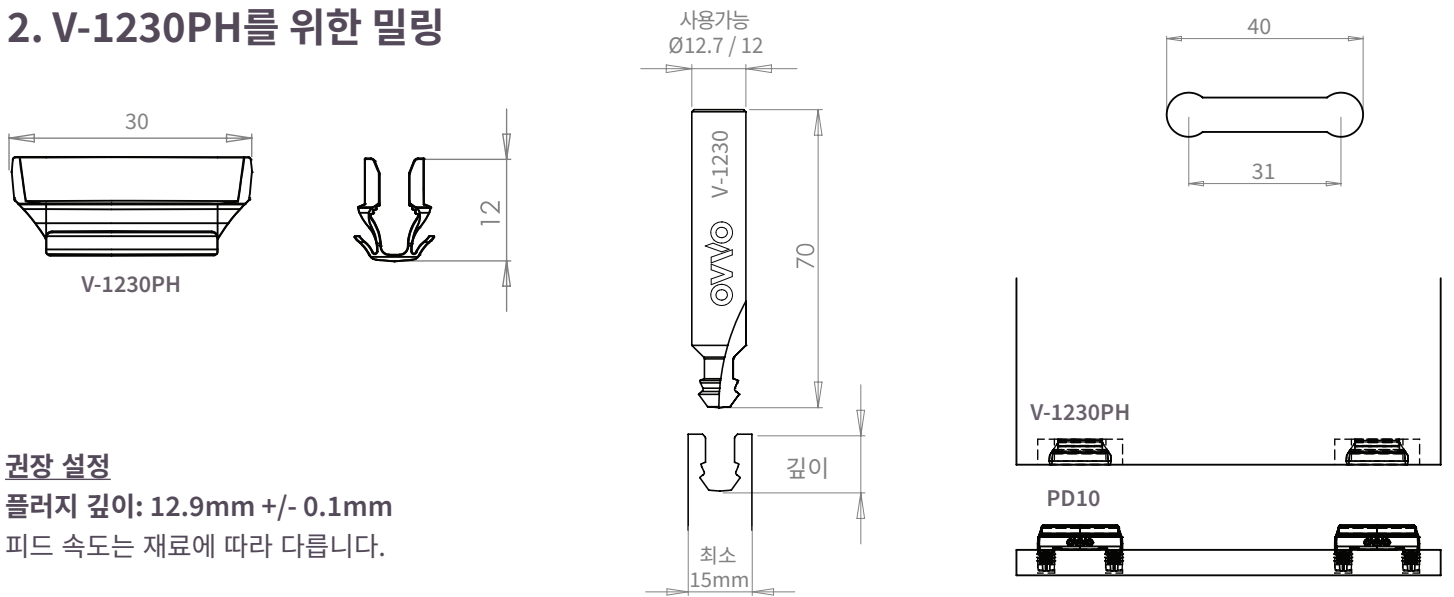

#### 권장 설정

플러지 깊이: 12.9mm +/- 0.1mm

피드 속도는 재료에 따라 다릅니다.

### 3. 조립

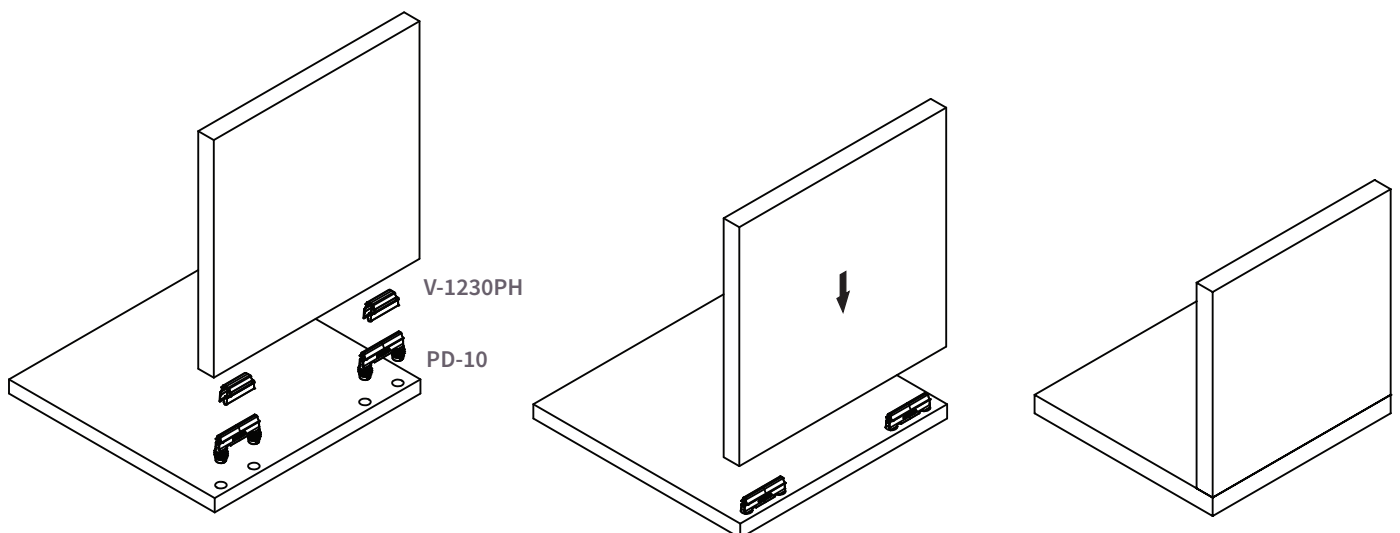

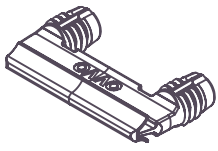

# 사용 지침

## PD10



### 1. PD10을 위한 드릴링

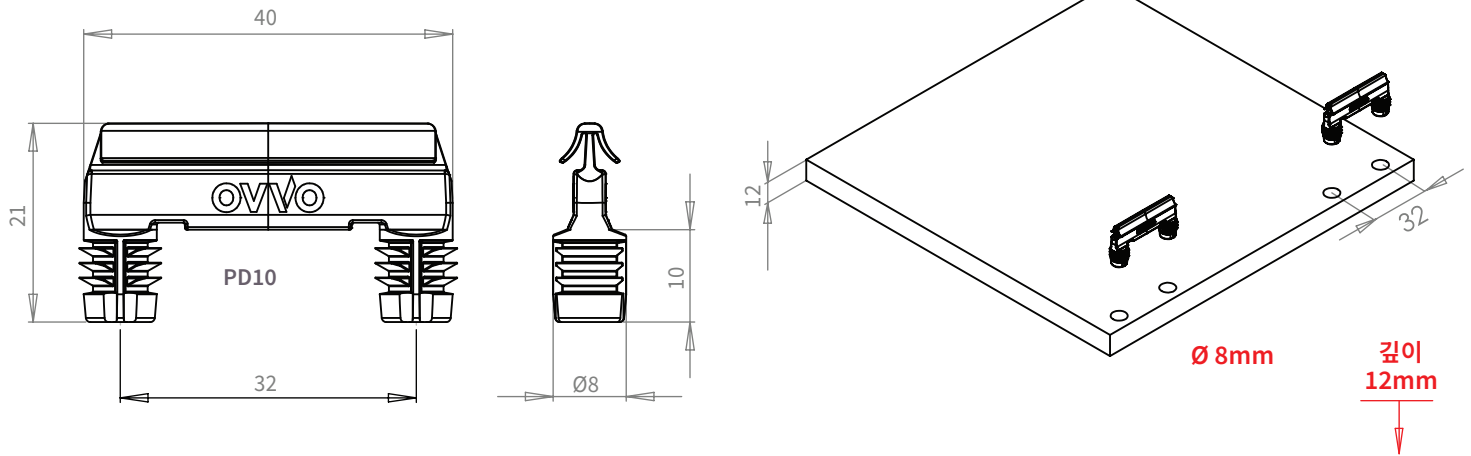

### 2. 밀링 예시

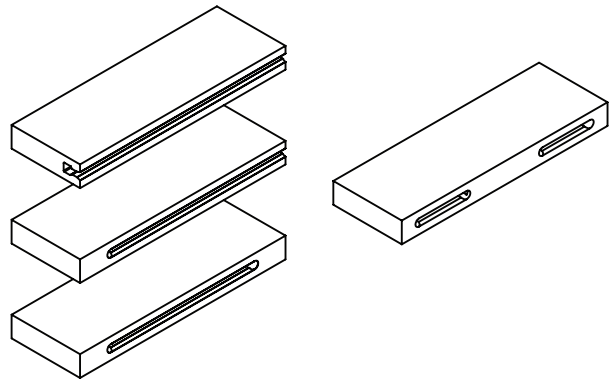
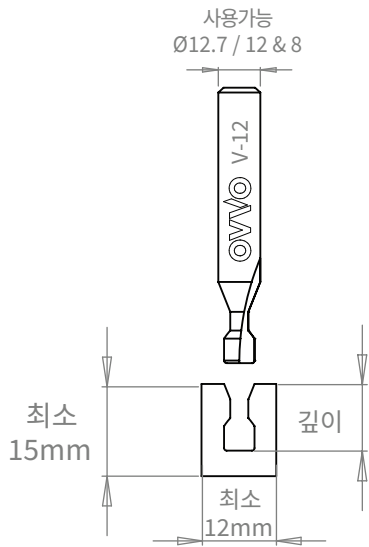

#### 권장 설정

플러지 깊이: 12.4mm +/- 0.1mm

피드 속도는 재료에 따라 다릅니다.

Tip: 플러지, 트래블, 초과 밀링 먼지 제거를 위한 후진 이동

### 3. 조립

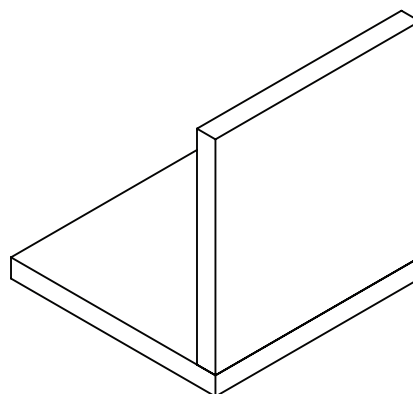
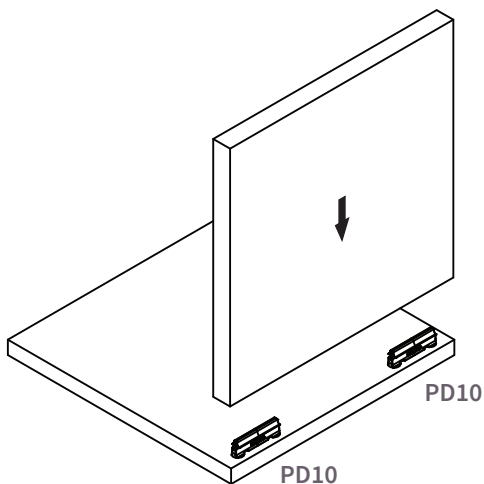

접착제와 함께 사용할 수 있습니다.